

KODEN

BUILT-IN BEACON RECEIVER DGPS RECEIVER MODULE

KBG-1/KBG-2

*Compact
State-of-the-art
DGPS receiver module.*



KBG-2



KBG-1

FEATURES

- **Now you can select the antenna from two types, E-field and H-field type**

Two types of antennas are prepared so that you may select the one best suited to your application. Especially the H-field type KBG-2 does not require special grounding connection and, thus, will be ideally matching to user's requirements for easy installation.

- **Differential GPS**

This receiver module upgrades your navigators such as the track display to the level of highly accurate DGPS navigation system. (GPS measurement is made outside the receivable range of differential GPS beacon signals.)

- **Easier operation**

Black box concept eliminates any need of control panel operation. Just connect the module to the track display, fish finder, marine radar or any desired navigator and it is ready for use.

- **Built-in data on beacon stations worldwide**

This module contains data on almost all beacon stations of the world including those being planned. It employs the position correction data of the world standard RTCM SC-104 format.

- **Automatic station selection**

Using the built-in beacon station data, this module selects the best station automatically without requiring manual setting.

- **Small and light**

Compact size and light weight features allow easier installation on a pleasure boat or small fishing boat.

- **Interface**

When interfaced with a navigator capable of communicating by MSK and MSS sentences in NMEA format, this module allows manual selection of desired beacon station for the position fix using DGPS.

SPECIFICATIONS

GPS receiver section

Receiving frequency	1575.42 MHz ±1 MHz
Receiving channel	Digital 11-channel parallel/sequential
Receiving code	C/A code
Sensitivity	Better than -130 dBm (elevation angle: 5° or over)
Accuracy	10 m RMS (at DGPS ON), 100 m 2DRMS (at DGPS OFF)
Position (PDOP ≤ 3)	0.1 knot RMS (at DGPS ON)
Velocity	0.1 knot RMS (at DGPS ON)

Note: Accuracy is subject to change in accordance with DoD civil GPS user policy.

Beacon receiver section

Receiving frequency	283.5 to 325.0 kHz
Receiving type	Double superheterodyne
Acquisition time	Auto: Less than 1 min. (bit rate: 200, S/N: 8 dB) Manual: Less than 30 sec. (bit rate: 200, S/N: 8 dB)
Antenna	Whip antenna (KBG-1), Ferrite-loop antenna (KBG-2)
Channel separation	500 Hz step
Modulation	MSK (bit rate: 50, 100, 200)
Sensitivity	Better than 10 µV/m
Signal to noise ratio (S/N)	6 dB or better
Dynamic range	92 dB
Station selection	Auto (required position information) or manual
Beacon station data (for automatic station selection)	Automatic beacon almanac entry, built-in station list in the world

GPS receiver section

Data Communication	Synchronous bidirectional data communication	
Input data format		
a) Baud rate	4800	
b) Programmable parameters	Different default setting: optional	
1) Antenna height	0 to 9999 m (Default: 0)	
2) Mask	Elevation	0° to 45° (Default: 10)
	Value	PDOP 0 to 30 (Default: 7)
		HDOP 0 to 20 (Default: 10)
		S/N 0 to 25 (Default: 3)
3) Datum	00 to 85 (Default: 00 WGS-84)	
4) Averaging factor	1 to 3 (Default: 3)	
5) L/L unit of GGA	0: 0.001' or 1: 0.0001' (Default: 1)	
6) Differential switch	0: OFF or 1: ON (Default: 1)	
7) Differential time out	10 to 180 sec. (Default: 100)	
8) Beacon station selection	A: Automatic, M: Manual (Default: A)	
9) Beacon receiving frequency	283.5 to 325.0 kHz	
10) Beacon data bit rate	50, 100, 200	
11) MSS sentence output interval	5 sec.	
c) Differential data	RTCM SC-104 format, 4800 baud	
d) Input data level	RS-232C	
Output data format	NMEA-0183 Ver. 2.0	Ver. 1.5 or other formats: optional
a) Baud rate	4800	2400 or 9600: optional
b) Data contents		
	Latitude and longitude (GGA)	In increments of 0.001 minute or 0.0001 minute (Default: 0.001 minutes)
	Time	UTC (hour, minute, second)
	Altitude	In increments of 1 meter
	Speed	In increments of 0.1 knot, 0.1 km/h
	Course	In increments of 0.1 degree
	Others	HDOP, position mode
c) Output format	RS-232C (Ver. 2.0)	GGA+GLL+GSV+VTG+RMC+ZDA+PKODA+PKODG, 1+PKODG, 7+GSA+MSK+MSS Interval of every 1 to 3 sec Once when CRQ,MSK is input Interval of every 10 sec
	RS-232C (Ver. 1.5)	GGA+GLL+PKODA+PKODG, 1+VTG+MSK+MSS Interval of every 1 to 3 sec Once when CRQ,MSK is input Interval of every 10 sec
	TTL (Ver. 2.0)	GGA+VTG+ZDA+MSK+MSS+SNU Interval of every 1 sec Interval of every 5 sec
	TTL (Ver. 1.5)	GGA+VTG+MSK+MSS+SNU Interval of every 1 sec Interval of every 5 sec
d) Output data level	RS-232C, TTL	
e) Output data current	40 mA or less (RS-232C), 10 mA or less (TTL)	
Backup memory	Retained by lithium battery	
Power supply	10.8 to 31.2 VDC	
Power consumption	5 W or less (at 12 VDC)	
Temperature range	Operation	-25° to +60°C (-13° to 140°F)
	Storage	-30° to +70°C (-22° to 158°F)

EQUIPMENT LIST

Standard Equipment List (KBG-1)

DGPS receiver module	KBG-1	E-field, with receiving antenna (0.5 m whip) and antenna cable (10 m, one end plain)	1.3 kg (2.9 lb)
Spare part kits	F-7142, 3A	For spare	1
Technical manual			1

Standard Equipment List (KBG-2)

DGPS receiver module	KBG-2	H-field, with antenna cable (10 m, one end plain)	1.6 kg (3.6 lb)
		H-field, with antenna cable (15 m, one end plain)	1.8 kg (4.0 lb)
Spare part kits	F-7142, 3A	For spare	1
Technical manual			1

Options

Connector	1005	5-pin	
	1006	6-pin	
Antenna holder	RAH-29	Ratchet mount	0.68 kg (1.5 lb)
Power rectifier	PS-003A	With two 5 A fuses	2.8 kg (6.2 lb)
Power cable	VV-2D8	Both ends plain	3 m (9 13/16 ft)

DIMENSIONS AND WEIGHT

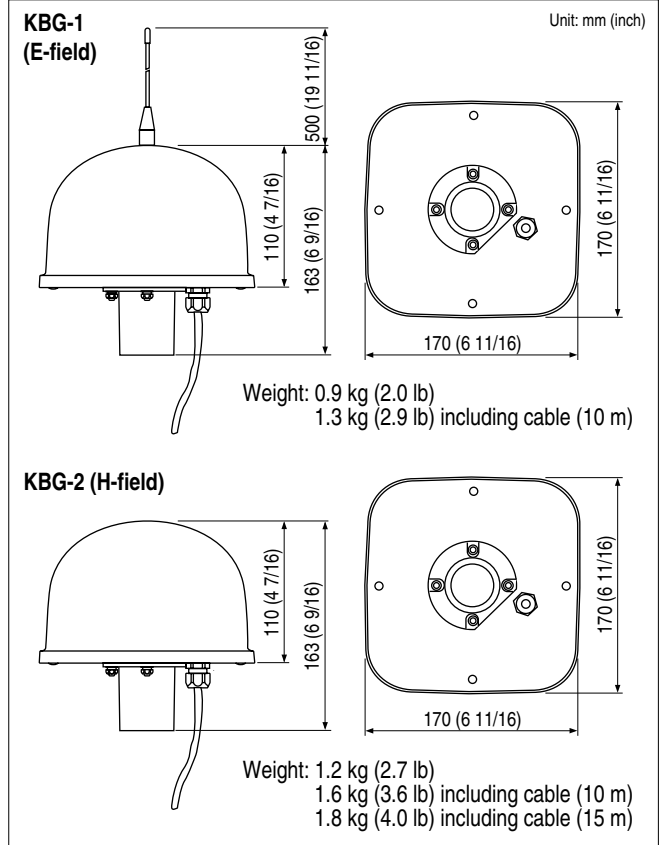

CONNECTION

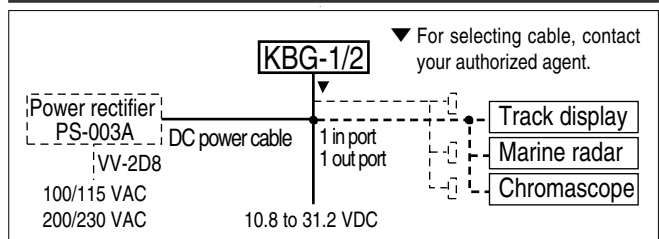

* Specifications subject to change without notice.

SELEX Communications Ltd
Marconi House
New Street
Chelmsford
Essex
CM1 1PL
United Kingdom

SELEX
Communications

a Finmeccanica Company

Tel: +44 (0)1245 275588
Fax: +44 (0)1245 275689
Email: marine-sales@selex-comms.com

www.selexmarine.com

Certified to ISO 9001 (TUV PRODUCT SERVICE)



Safety precaution

To ensure proper and safe use of the equipment, please carefully read and follow the instructions in the OPERATION MANUAL.

FOR DETAILS, PLEASE CONTACT:

OKBG1/2-01 97 XII MI 3Y1
OKBG1/2-03 99 VI MI 2Y3
PRINTED IN JAPAN