

*Fully compliant with New IMO requirements*



## FEATURES

### Compliant with New IMO

Meeting with New IMO requirements MSC.112(73) and IEC 61108-1 Ed.2 for SOLAS carriage requirements. Approved for U.S. Coast Guard Module B.

### GNSS sensor of AIS

The KGP-920 GPS Navigator can be used as a GNSS sensor of AIS.

### SBAS ready

The satellite based positioning correction system will be fully operated within a few years time. The systems called WAAS (USA) and EGNOS (EU) are in trial phase which services are broadcast now. MSAS (ASIA) is expected soon too.

### Quick positioning

The true parallel 18 channel GPS receiver provides precise and quick positioning at any time.

### Optional Beacon DGPS

The built-in beacon receiver is available as an option. It can be used as a high-accuracy differential GPS navigator.

## SPECIFICATIONS

### GPS receiver

Receiving frequency	1575.42 MHz
Receiving channel	18 channel parallel
Receiving code	C/A code
Sensitivity	Better than -130 dBm (elevation angle: 5° or over)
Accuracy	Position 10 m 2drms (GPS), 5 m 2drms (DGPS), 8 m 2drms (SBAS)
	SOG 0.1 kt rms
(HDOP ≤ 4)	COG ±3° (SOG 1-17 kt), ±1° (SOG >17 kt)

Note: Accuracy is subject to change in accordance with DoD civil GPS user policy.

### Display section

Display	LCD with backlight (128 x 64 dots, effective picture area: 85.71 x 54.35 mm)
Display mode	Standard text (NAV1), Navigation graph (NAV2), 3-D Highway (NAV3), Simple plotter (PLOT), MOB (Man Over Board)
Position data display	Latitude/longitude in increments of 0.0001 minute, converted Loran C LOPs, converted Loran A LOPs, converted Decca LOPs
Instant (event) memory	200 points
Waypoint memory	200 points
Route memory	20 routes (Max. 400 waypoints) reverse trail possible
Alarm	Proximity, Cross track error, CDI, Anchor watch
Position compensation	Latitude/longitude, LOPs, Datum
Magnetic compensation	Auto or manual
Power supply	10.8 to 31.2 VDC
Power consumption	4.5 W or less (at 24 VDC)

### Environment

Operating temperature	Display unit: -15° to +55° Antenna unit: -25° to +70°
Waterproofing	Display unit: IPX4 Antenna unit: IPX6

### Data Input/Output

Output data format (DATA connector)	IEC 61162-1 / NMEA 0183 Ver.1.5 (NMEA1, 2) / CIF / SHIPMATE (AAM, APB, BOD, BWC, DCN, DTM, GBS, GGA, GLC, GLL, GNS, GSA, GSV, MSS, RMB, RMC, Rnn, RTE, SGR, VTG, WDC, WPL, XTE, ZDA)
Output data format (DATA2 connector)	IEC 61162-1 (AAM, APB, BOD, BWC, DCN, DTM, GBS, GGA, GLC, GLL, GNS, GSA, GSV, MSS, RMB, RMC, Rnn, RTE, SGR, VTG, WDC, WPL, XTE, ZDA)
Input data format	RTCM SC104 Ver.2.0 (DGPS)

## EQUIPMENT LIST

### Standard Equipment

Display unit	KGP-920	With mounting bracket and vinyl cover	0.86 kg	1
Antenna unit	GA-08	For GPS reception, with 10 m antenna cable with BNC connector	0.62 kg	1
	GA-08L	For GPS reception, with 15 m antenna cable with BNC connector	0.81 kg	
	GA-08S	For GPS reception, with 0.5 m antenna cable with N-P connector	0.26 kg	
DC power cable, installation material, spare fuses, and operation manual				1 set

### Main Options

Internal beacon receiver kit	Int-DGPS kit factory built-in only	Receiver PCB, Connector, Harness	-
Beacon antenna unit	BA-02 / BA-03	E-field type / H-field type	-
Receiving antenna	RA-14	2.45 m whip for BA-02	0.3 kg
Hose band	738-1015	For antenna unit	-
Connecting cable	CW-373-1-5M/10M	6 pin waterproof connector	5 m / 10 m
Flush mount kit	FMK-1	Flush mount frame with screws	-
Antenna cable extension kit	CW-839-30M kit	5 DFB cable with N-J connector one end and a loose N-J connector	30 m
Antenna cable extension kit	CW-394-60M kit	8 DSFA cable with N-J connector one end and a loose N-J connector	60 m
Conversion cable	CW-826	One end with N-P connector and the other end with BNC connector	0.5 m

## CONNECTIONS

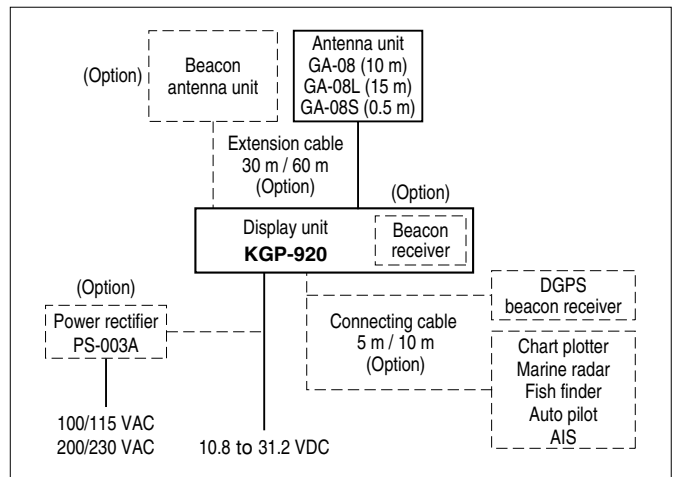

## DIMENSIONS AND WEIGHT

<b>Display unit</b>  Unit: mm (inch) Weight: 0.86 kg (1.9 lb)	<b>Antenna unit (GPS) GA-08/08L/08S</b>  Weight: GA-08: 0.19 kg (0.42 lb) without cable GA-08: 0.62 kg (1.4 lb) including cable (10 m) GA-08L: 0.81 kg (1.8 lb) including cable (15 m) GA-08S: 0.26 kg (0.57 lb) including cable (0.5 m)	<b>Antenna unit (beacon) BA-02-K/02-KL/02-KS</b>  Weight: BA-02-K: 0.4 kg (0.89 lb) without cable BA-02-K: 0.85 kg (1.9 lb) including cable (10 m) BA-02-KL: 1.2 kg (2.7 lb) including cable (15 m) BA-02-KS: 0.33 kg (0.7 lb) including cable (0.5 m)	<b>Antenna unit (beacon) BA-03/03L/03S</b>  Weight: BA-03: 0.92 kg (2.1 lb) without cable BA-03: 1.4 kg (3.1 lb) including cable (10 m) BA-03L: 1.6 kg (3.6 lb) including cable (15 m) BA-03S: 0.99 kg (2.2 lb) including cable (0.5 m)
--	--	--	---

\* Specifications subject to change without notice.

SELEX Communications Ltd  
 Marconi House  
 New Street  
 Chelmsford  
 Essex  
 CM1 1PL  
 United Kingdom

**SELEX**  
 Communications

a Finmeccanica Company

Tel: +44 (0)1245 275588  
 Fax: +44 (0)1245 275689  
 Email: marine-sales@selex-comms.com

[www.selexmarine.com](http://www.selexmarine.com)

**Safety precaution**  
 To ensure proper and safe use of the equipment, please carefully read and follow the instructions in the OPERATION MANUAL.

For details, please contact: